



RK-55

NEW

Worldwide products.

Higher Quantity
and Lower Price.



A handy large table!!
Pieces, tools and buckets are allable on the large table.



• MAX 12kg centering capacity.

- Only 23kg! Convenient to carry.
- Tension adjustment is available, if the belt is extended.
- Three Legs design increases stability.



Easy-to-operate foot pedal smoothly.

Model	RK-55
Motor	100W AC230V 50Hz single phase
Drive System	DC Motor with Brush
Wheelhead speed	0-250rpm
Speed control	Remote Foot Pedal
Wheelhead Direction	Clockwise/Counter-Clockwise
Wheelhead	Light alloy casting,diameter 300mm
Dimension	W560 × D720 × H540
Total Weight	23kg
Power supply code	1.8m
Accessory	Two piece Splash Pan

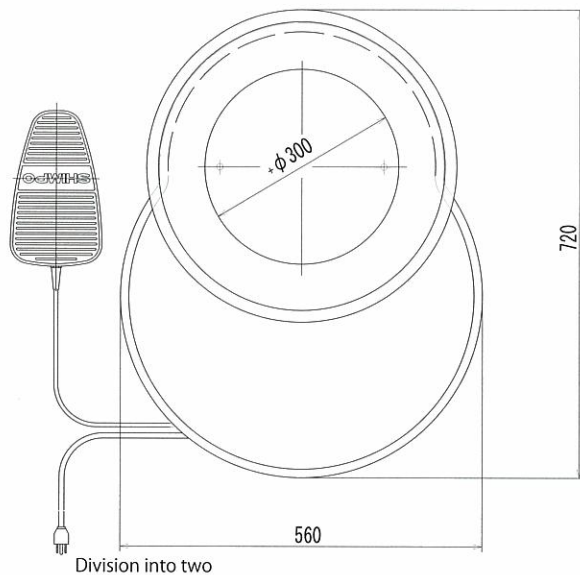
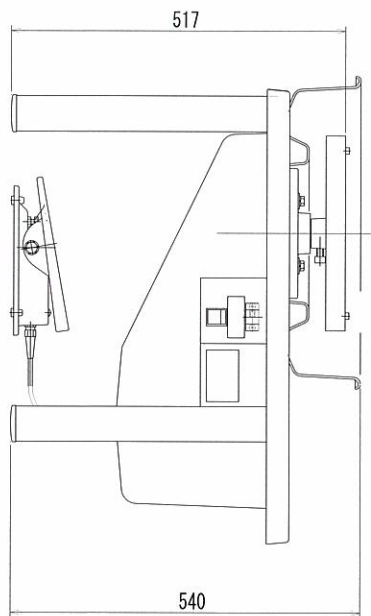

SHIMPO —All for dreams

<http://www.nidec-shimpo.co.jp/>

NIDEC-SHIMPO CORPORATION

1 Terada, Kohtari, Nagaokakyo-City, Kyoto, Japan

Phone: 075-958-3608 FAX: 075-958-3647